

Concentrated NCG (CNCG)

Low Volume, High Concentration (LVHC) Gas Systems

Kraft pulp mills must collect and incinerate their odorous non-condensable gases in order to minimize odour and to comply with the environmental regulations. Great care must be taken when designing and operating concentrated NCG systems; the gases are corrosive, toxic and potentially explosive.

NORAM offers comprehensive services in CNCG/LVHC gas systems:

- Audits of existing operation, including troubleshooting and debottlenecking
- Revised logic and control strategies (e.g. ventless transfer between incineration devices)
- Process Safety Management (PSM)/HAZOP analysis

NORAM systems focus on the following:

- Safety and reliability
- Innovative and effective designs
- Low capital and maintenance costs

Concentrated NCG contains total reduced sulfur gases (TRS), methanol, and terpenes that are released from digesters, turpentine recovery systems, strippers and multiple effect evaporators. CNCG/LVHC gases are collected and maintained at all times above their upper explosive limit (UEL).

NORAM offers a reliable system with multiple levels of protection, which fully accounts for the toxic, corrosive and flammable nature of these gases. Our paramount design philosophy is to prevent air ingress into the system. Various features are provided to ensure that even during an upset condition safety is not seriously jeopardized:

NORAM system design

- All sources collected are properly sealed
- Water-sealed pressure/vacuum breakers protect equipment and piping during upsets
- Steam ejectors motivate the CNCG and further dilute any oxygen that may be present
- Flame arresters prevent flame propagation
- Rupture discs provide instantaneous pressure relief in the unlikely event of a sudden overpressure
- Fall-safe logic and controls ensure that CNCG will safely vent if a major upset occurs

Other design details include proper piping layout for effective condensate collection, suitable location of rupture discs, providing back-up incineration options, etc. A hazard and operability study (HAZOP) is always conducted by a group of NORAM engineers to ensure safety and reliability.

Once the CNCG/LVHC gases are effectively collected they can be combusted in one of a variety of devices, including existing mill equipment such as lime kilns, power boilers, recovery boilers, or in new equipment such as dedicated incinerators equipped with SO₂ scrubbers and optional heat recovery.

NORAM is experienced with all of these options for incineration and are available to help determine which is the best system for your mill.

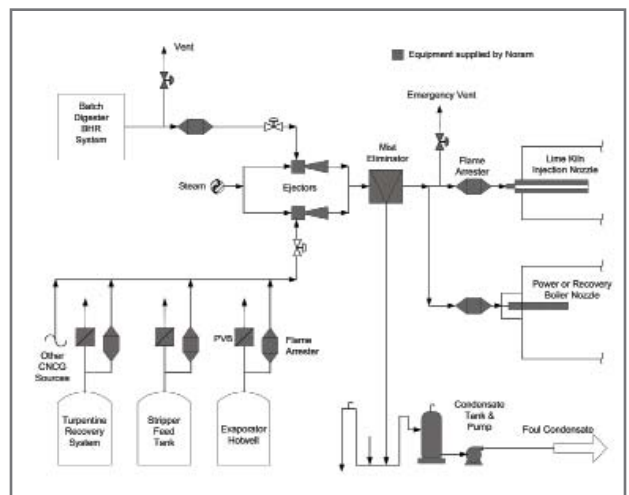

Typical Concentrated NCG System

technology and engineering solutions for the process and resource industries



Nitration



Sulfuric Acid



Electrochemical

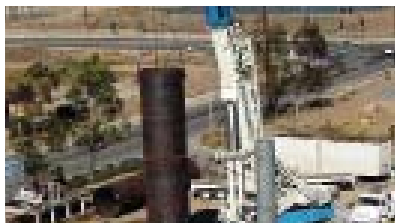

Biosystems



Pulp&Paper



Environmental

Company Profile

NORAM is a private engineering and technology firm based in Vancouver BC, Canada. We specialize in the development, engineering and commercialization of new chemical processes, and in the improvement and optimization of existing technologies. Since 1988 NORAM has provided leading-edge technologies to the chemical, pulp and paper, minerals processing, wastewater and electrochemical industries.

Today NORAM is the world's leading supplier of nitration technology. In addition, we offer sulfuric acid plants, biological treatment facilities, energy systems, and technologies for the clean-tech sectors.

Our business has developed around the supply of proprietary engineering and equipment packages to our clients.

Core competencies include:

- Nitration and NO_x Technology
- Electrochemical Systems
- Sulfuric Acid Manufacture
- Biological Wastewater Treatment
- Computational Fluid Dynamics & Finite Element Analysis
- Heat Transfer & Heat Exchangers
- Hydrogen, Sulfur and Chlorine Chemistry
- Fluidised Bed Systems
- Energy Storage
- System Closure

Partnering with Innovation and Experience

NORAM works extensively with early-stage technology companies. We draw on established competencies in process design and engineering, provide custom in-house fabrication capabilities, and offer pilot plant and contract research facilities to support the commercialization process.

We've teamed up with organizations around the globe to allow project execution on 5 continents. Our strategic relationships include:

- Bateman Engineering BV
- Canadian Hydrogen and Fuel Cell Association
- ECO-TEC Inc.
- First Chemical Corporation (a DuPont Company)
- FP Innovations
- Kemetco Research Inc.
- Membrane Reactor Technologies
- Ostara Nutrient Recovery Technologies Inc.
- Radiant Technologies Inc.
- Siloxy Limited
- Simon Carves Ltd (Punj Lloyd Group)
- Electrosynthesis Company Inc.

www.noram-eng.com



NORAM Engineering and Constructors Ltd.

Suite 1800 - 200 Granville Street
Vancouver, British Columbia
Canada V6C 1S4

Telephone: +1.604.681.2030
Facsimile: +1.604.683.9164